

## PRODUCT DATASHEET

### AutroGuard® conduit boxes BWP-100/20/AG and BWP-100/25/AG

#### Features

- Designed for AutroGuard® protectors
- Protects the connections to the protectors in humid environments
- Easy to mount the protector base onto the conduit box

#### Description

The AutroGuard® conduit boxes BWP-100/20/AG and BWP-100/25/AG are used for the installation of protectors in environments that may be humid/wet, such as engine rooms, workshops, storerooms, etc.

A click-type cable gland is included. The use of cable glands provides an ingress protection level of IP55.

The BWP-100/20/AG has two pre-made openings.

The boxes are designed for use with Autronica's interactive fire detection systems.

The conduit boxes (see drawing below and part numbers) have a total of six 20 or 25 mm knockouts; 2 at the bottom and 4 around the sides located at 90, 180, 270 and 360 degrees.

The standard AutroGuard protector base is easily mounted onto the conduit box.

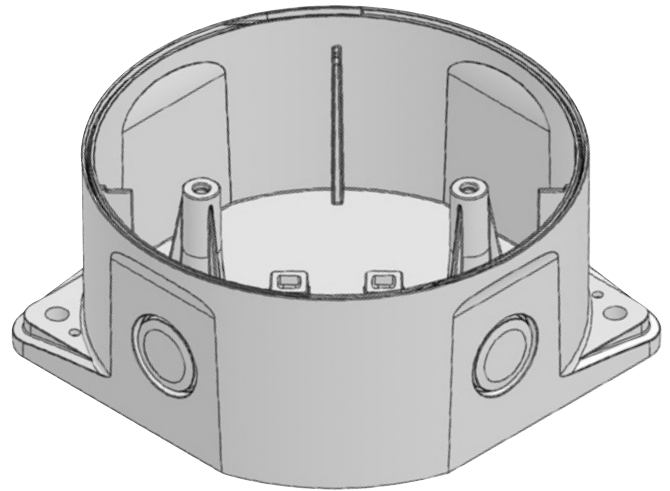

Part number	Description
116-BWP-100/20/AG	Conduit Box, 20mm
116-BWP-100/25/AG	Conduit Box, 25mm

Spare parts	Description
116-100001400	GLAND - SKINTOP CLICK 25, Light grey

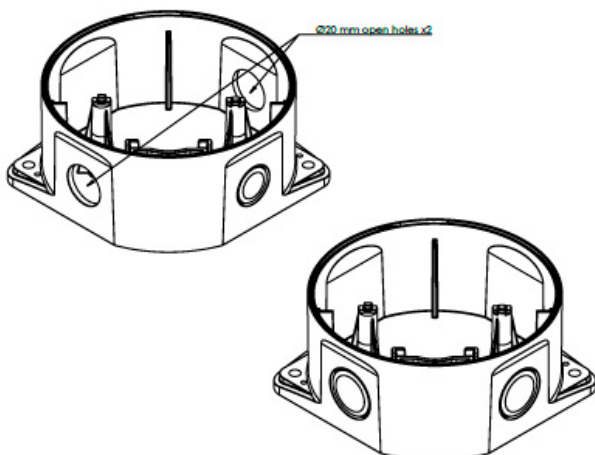

#### Technical specifications

Weight BWP-100/20/AG	140g
Weight BWP-100/25/AG	175g
Material	Self-extinguishing polycarbonate
Colour	RAL 9010 White
Degree of protection	IP55
Maintenance	None

Dimensions (mm)

