

# CONTROL AND MONITORING UNIT BN-305-D

## Interactive fire detection systems Product Datasheet

### Features

- Interactive.
- Interface unit for interfacing external units to the Autroprime or AutoSafe fire alarm systems.
- Multi-function unit: Function selected by switch setting on BNA-305-D and strappings on the BN-305-D module.
- Control of up to ten doors with proximity sensors
- Outputs: When controlling doors, turns on and off 24V for door magnets. When used for low location lighting, the outputs are potential free relay contacts.
- Inputs: Activates with 24V signals. Intended for use with two and three wire proximity sensors for 24V. Both PNP and NPN type sensors are supported.
- Short circuit isolator in each BNA-305-D unit.
- Automatic addressing.
- Proven technology.
- Designed to meet the requirement of the major mari-time classification societies.
- DIN-Rail mounted
- Designed according to EN-54p17:2005 EN-54p18:2005
- 1A 30 VDC dry relay contact for the output ports.



### Description

The unit has been designed for use with Autronica's interactive fire detection systems, Autroprime and AutoSafe, and includes the SelfVerify® function.

This function ensures the highest grade of reliability and reduces the need for manual testing because the panel is able to continuously and automatically check all units that include this function.

Note: External devices attached to this interface unit require a separate power source (they cannot be powered by the detector loop).

Technical specifications	
Dimensions (mm)	125 x226 x123
Weight (g)	1225g (including 5 pcs BNA-305-D)
Housing material	Polyamide 6.6 and AluZinc
Mounting	DIN Rail mounting BN-305-D shall be installed in an external enclosure which has an IP grade of at least IP66 and a total mass of more than 4.75kg.
Power supply	Proximity Sensor 24V supply Max 0.25A (Controlling 10 doors)
	MAIN +24V Controlled from the bridge Max 2.15A (Controlling 10 doors)
	STEADY +24 Max 2.32A (Controlling 10 doors with two door leafs each)
Temperature range	-25 to +70 °C
Humidity	10% - 95% RH (non-condensing)
Degree of protection	IP20 (without external enclosure)
Communication loop protocol	Autronica Loop Communication protocol (AL_Com)
Cable terminals	X30 Max 6 mm <sup>2</sup> single core wires All others Max 2.5 mm <sup>2</sup> single core wires
Cable requirements AL_Com	Refer to specification for AutoSafe or AutoPrime
Maximum input cable length	100m
Maximum cable capacitance	1uF
Serial impedance Z <sub>c</sub> Max	40mΩ
Output relay rating	1A 30VDC
Output relay type	Dry contact, Latching type; keep state on loss of power. No EOL monitoring
Approvals	See website

Product Name	Part Number	Description
BN-305-D	116-BN-305-D	Control and Monitoring Unit
BNA-305-D	116-BNA-305-D	Plugin card for BN-305-D (Max 5 per module)

## Dimension Drawing and mounting

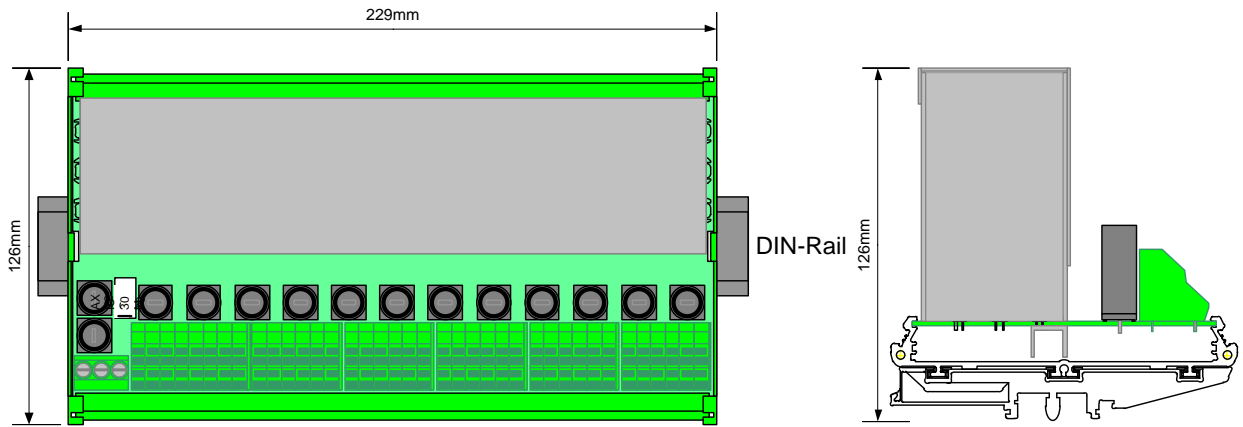

## Component Drawing

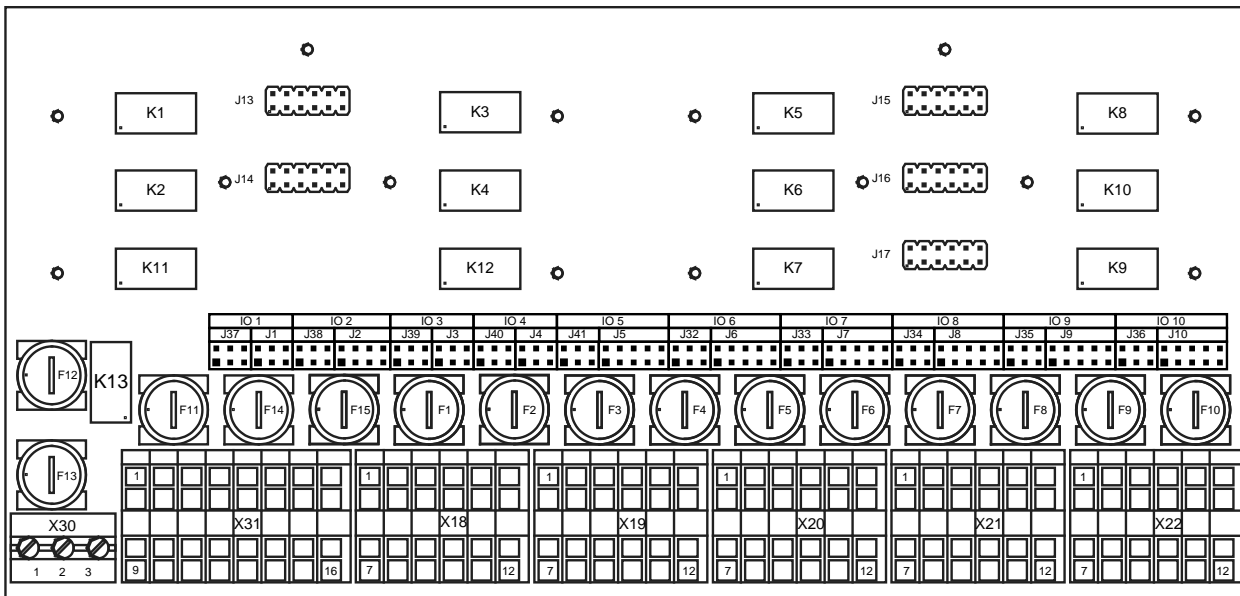

## Card positions vs possible functions

Table 1

Terminal	Card Position	Function	
J13	1	IO 1 (Door)	
		IO 2 (Door) or 24V supply proximity switches monitoring	
J14	2	IO 3 (Door)	
		IO 4 (Door)	
J15	3	IO 5 (Door)	LLL 1
		IO 6 (Door)	
J16	4	IO 7 (Door)	LLL 2 (1)
		IO 8 (Door)	
J17	5	IO 9 (Door)	LLL 3 (2) (1)

### Configuring the BNA-305-D for different functions

When installing the BNA-305-D, make sure that the DIP switch settings on the BNA-305-D is set correctly. This must be specified by the engineering department as the functionality is dependent on the given project and application where the unit is used.

There is a special setting for card position 1, used for monitoring the 24V for the proximity switches:

Set BNA-305-D to “Function M”, “Input Configuration C” and the output relay set to normally closed. IO 1 is used as door and IO 2 is used to monitor the voltage. Field connector J18.7 to J18.12 must remain unconnected. This setting can only be used in the first card position.

Door Control, two doors per BNA-305-D with one door sensor each:

Set BNA-305-D to “Function K”, “Input Configuration C” and the output relay set to normally closed. This setting can be used in all the five card positions.

Door Control, one door per BNA-305-D with two door sensors per door:

Set BNA-305-D to “Function L”, “Input Configuration C” and the output relay set to normally closed. This setting can be used in all the five card positions.

Low-Location-Lighting or lift control:

Set BNA-305-D to “Function M”, “Input Configuration C” and the output relay set to normally closed. This setting can only be used in card positions 3, 4 and 5. If only one LLL is used, the function must be in card position 5. If two LLL is used, the function must be in card position 4 and 5. This is due to the possible combinations of settings on the board. In this case the strapping on the BN-305-D is set for potential free relay output contacts.

**Function K**

<b>S1.1</b>	<b>S1.2</b>	<b>S1.3</b>	<b>S1.4</b>
<b>OFF</b>	<b>ON</b>	<b>OFF</b>	<b>ON</b>

Function: Relay output function with activation feedback monitoring. Default delay for change of position is 17 seconds. At activation there is a 30 seconds delay before a technical alarm is initiated. When the door closes an indication of this status is given. When the door is closed, an indication of this status is sent after 120 seconds. All delays are configurable.

Number of addresses: 2

Applications:

- Door control and monitoring
- Fire damper control and monitoring
- Low location lights control and monitoring
- Other equipment

**Function L**

<b>S1.1</b>	<b>S1.2</b>	<b>S1.3</b>	<b>S1.4</b>
<b>ON</b>	<b>ON</b>	<b>OFF</b>	<b>ON</b>

Function: Relay output function with activation feedback monitoring (output 2 not in use).

Both inputs are used to achieve monitoring of both end positions

Number of addresses: 1

Applications:

- Door control and monitoring
- Fire damper control and monitoring
- Other equipment

**Function M**

<b>S1.1</b>	<b>S1.2</b>	<b>S1.3</b>	<b>S1.4</b>
<b>OFF</b>	<b>OFF</b>	<b>ON</b>	<b>ON</b>

Function: Relay output function with activation feedback monitoring (output 2 not in use).

The second input is used for external fault input.

Number of addresses: 1

Applications:

- Door control and monitoring
- Fire damper control and monitoring
- Low location lights control and monitoring
- Other equipment

**Input configuration C** activates when the contacts are closed. This arrangement allows the unit to monitor for an open circuit fault in the electrical wiring before activation. A short-circuit in the wiring will trigger the unit.

<b>S1.5</b>	<b>S1.6</b>
<b>ON</b>	<b>OFF</b>

**Output configuration** can be set to Normal Open or Normal Closed operation by DIP switch 1.7:

- DIP 1.7 OFF = Normally open
- DIP 1.7 ON = Normally closed

DIP switch 1.8 determines the state of output if the unit loses its power.

- DIP 1.8 OFF = Relay remains in current state
- DIP 1.8 ON = Relay switches to initial state as chosen by DIP 1.7

## Using the LED indicators on BNA-305-D to adjust the proximity sensors

The green LED on the BNA-305 indicates activation. This LED is combined for both inputs and both outputs. When adjusting the door sensor, do a local release of the door. As the relay is normally not activated i.e. "Normally closed", the green indicator is off. Once the door sensor is adjusted correctly, the green led will activate. When using this procedure for a BNA-305-D with two different doors, only one door should be released locally at one time to get correct indication of the LED. If both doors are released at the same time the LED will be activated as long as one of the door sensors is correctly adjusted.

## Using less than five BNA-305-D boards in the control module

The door control module can have 1 to 5 BNA-305-D boards mounted. Populate the door control module with BNA-305-D from position 1 and onward.

When using less than 5 x BNA-305-D boards straps must be placed to connect the AL\_Com Out - to X31.16

Table 2

Terminal	Description
J17.1	Strap when using 4 or less BNA-305-D
J17.3	
J16.1	Strap when using 3 or less BNA-305-D
J16.3	
J15.1	Strap when using 2 or less BNA-305-D
J15.3	
J14.1	Strap when using 1 BNA-305-D
J14.3	

It is also possible to have for example the following configuration, three doors, monitoring of 24V for proximity switches and one low location lighting. Card position 3 and 4 is not populated.

Table 3

Terminal	Description
J16.1	Strap
J16.3	
J15.1	Strap
J15.3	

## Pin numbering for the configuration straps

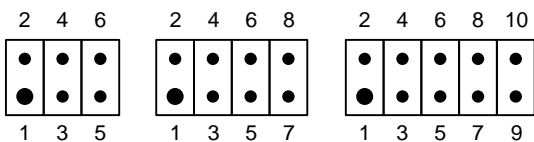

### Configuring the inputs for different types of proximity sensors and LLL/Lift

The proximity sensor interface can be configured to handle two wire sensors and three wire sensors with both PNP and NPN signal outputs. This is done by placing the straps as shown in the following table.

Table 4

Sensor 1	J37.1	J37.3	J37.5	J37.2	J37.4	J37.6
Sensor 2	J38.1	J38.3	J38.5	J38.2	J38.4	J38.6
Sensor 3	J39.1	J39.3	J39.5	J39.2	J39.4	J39.6
Sensor 4	J40.1	J40.3	J40.5	J40.2	J40.4	J40.6
Sensor 5	J41.1	J41.3	J41.5	J41.2	J41.4	J41.6
Sensor 6	J32.1	J32.3	J32.5	J32.2	J32.4	J32.6
Sensor 7	J33.1	J33.3	J33.5	J33.2	J33.4	J33.6
Sensor 8	J34.1	J34.3	J34.5	J34.2	J34.4	J34.6
Sensor 9	J35.1	J35.3	J35.5	J35.2	J35.4	J35.6
Sensor 10	J36.1	J36.3	J36.5	J36.2	J36.4	J36.6
NPN or 2 wire sensor	Strap (Default)				Strap (Default)	
PNP sensor		Strap		Strap		

#### Strapped and connected as three wire NPN sensor

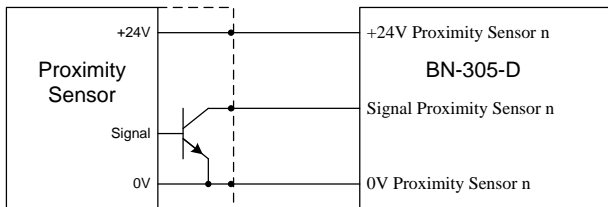

#### Strapped and connected as two wire sensor

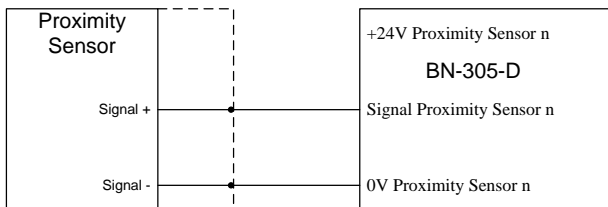

#### Strapped and connected as three wire PNP sensor



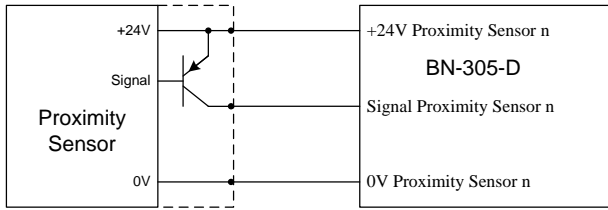

When used for LLL/Lift the input must be strapped as two wire sensor. The activation read back status must be connected to IO 5, 7 or 9 using the Normally Open output of the LLL/Lift unit.

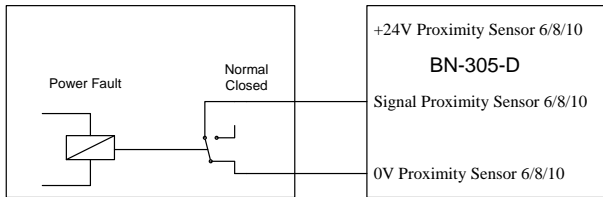

When used for LLL/Lift the input must be strapped as two wire sensor. The power fault output of the LLL/Lift must be connected to IO 6, 8 or 10 using the Normally Closed output from the LLL/Lift unit

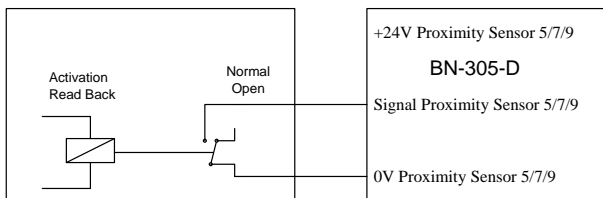

## Outputs

When the outputs is used for door magnets, relay coils and other inductive loads it is important that there is a reverse diode to prevent arcing and fusing of the relay contacts.

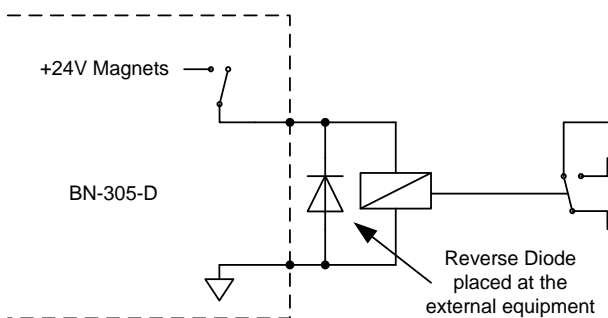

## Door control settings

The doors can be remotely controlled from three different fire zones, FZ. Local, forward and aft. See Table 14 for connection to and from the different fire zones. This functionality is used to override the normal loop control.

Table 5 Door 1:

	Description	
J1.1	Strap for local FZ control. Set as default	Only one strap at once
J1.2		
J1.3	Strap for FWD FZ control	
J1.4		
J1.5	Strap for AFT FZ control	
J1.6		

Table 6 Door 2:

This door position has an alternative use as monitoring of the 24V for the proximity switches. When used as monitoring, this IO can not be used for door control.

	Description	
J2.1	Strap for local FZ control. Set as default	Only one strap at once  Remove when used for monitoring
J2.2		
J2.3	Strap for FWD FZ control	
J2.4		
J2.5	Strap for AFT FZ control	
J2.6		
J2.7	Strap when used for monitoring the 24V for the proximity sensors	
J2.8		

Table 7 Door 3:

	Description	
J3.1	Strap for local FZ control. Set as default	Only one strap at once
J3.2		
J3.3	Strap for FWD FZ control	
J3.4		
J3.5	Strap for AFT FZ control	
J3.6		

Table 8 Door 4:

	Description	
J4.1	Strap for local FZ control. Set as default	Only one strap at once
J4.2		
J4.3	Strap for FWD FZ control	
J4.4		
J4.5	Strap for AFT FZ control	
J4.6		

Table 9 Door 5/6 or LLL:

	Description	
J5.1	Strap for local FZ control. Set as default	Only one strap at once
J5.2		
J5.3	Strap for FWD FZ control	Remove strap when used as LLL/LIFT
J5.4		
J5.5		
J5.6	Strap for AFT FZ control	
J5.7	Strap for LLL	
J5.8		
J5.9	Remove Strap for LLL	
J5.10		

	Description	
J6.1	Strap for local FZ control. Set as default	Only one strap at once
J6.2		
J6.3	Strap for FWD FZ control	Remove strap when used as LLL/LIFT
J6.4		
J6.5		
J6.6	Strap for AFT FZ control	
J6.7	Strap for LLL	
J6.8		
J6.9	Remove Strap for LLL	
J6.10		

Note, if three LLL is needed, this is the first position

Table 10 Door 7/8 or LLL:

	Description	
J7.1	Strap for local FZ control. Set as default	Only one strap at once
J7.2		
J7.3	Strap for FWD FZ control	Remove strap when used as LLL/LIFT
J7.4		
J7.5		
J7.6	Strap for AFT FZ control	
J7.7	Strap for LLL	
J7.8		
J7.9	Remove Strap for LLL	
J7.10		

	Description	
	Description	
J8.1	Strap for local FZ control. Set as default	Only one strap at once
J8.2		
J8.3	Strap for FWD FZ control	Remove strap when used as LLL/LIFT
J8.4		
J8.5		
J8.6	Strap for AFT FZ control	
J8.7	Strap for LLL	
J8.8		
J8.9	Remove Strap for LLL	
J8.10		

Note, if two LLL is needed, this is the first position

Table 11 Door 9/10 or LLL:

	Description	
J9.1	Strap for local FZ control. Set as default	Only one strap at once
J9.2		
J9.3	Strap for FWD FZ control	Remove strap when used as LLL/LIFT
J9.4		
J9.5		
J9.5	Strap for AFT FZ control	

J9.6		
J9.7	Strap for LLL	
J9.8		
J9.9	Remove Strap for LLL	
J9.10		

	Description	
J10.1	Strap for local FZ control.	Only one strap at once
J10.2	Set as default	
J10.3	Strap for FWD FZ control	Remove strap when used as LLL/LIFT
J10.4		
J10.5	Strap for AFT FZ control	
J10.6		
J10.7	Strap for LLL	
J10.8		
J10.9	Remove Strap for LLL	
J10.10		

Note, if one LLL is needed, this is the first position

## Fuses

Table 12

Fuse	Rating	Function
F1	0.63AF	IO 1 Door Magnet 1
F2	0.63AF	IO 2 Door Magnet 2
F3	0.63AF	IO 3 Door Magnet 3
F4	0.63AF	IO 4 Door Magnet 4
F5	0.63AF	IO 5 Door Magnet 5
F6	0.63AF	IO 6 Door Magnet 6
F7	0.63AF	IO 7 Door Magnet 7
F8	0.63AF	IO 8 Door Magnet 8
F9	0.63AF	IO 9 Door Magnet 9
F10	0.63AF	IO 10 Door Magnet 10
F11	3.15AF	Main Fuse Steady+
F12	3.15AF	Main Fuse +24V
F13	0.20AF	AFT FZ Control Output
F14	0.20AF	FWD FZ Control Output
F15	0.50AF	+24V Proximity Sensors

Note: All fuses is 5x20mm glass tube fast-blow type

## Connectors

Table 13 Main power supply connector

Terminal	Function
X30.1	Main +24V
X30.2	Steady +
X30.3	Common 0V

Table 14 Zone control, proximity sensor power supply and loop connector

Terminal	Function
X31.1	+24V FWD FZ Control Input
X31.2	0V FWD FZ Control Input
X31.3	+24V AFT FZ Control Input
X31.4	0V AFT FZ Control Input
X31.5	+24V FWD FZ Control Output

X31.6	0V FWD FZ Control Output
X31.7	+24V AFT FZ Control Output
X31.8	0V AFT FZ Control Output
X31.9	+24V Proximity Sensor Supply In
X31.10	0V Proximity Sensor Supply In
X31.11	+24V Proximity Sensor Supply Out
X31.12	0V Proximity Sensor Supply Out
X31.13	AL_COM Loop + In
X31.14	AL_COM Loop – In
X31.15	AL_COM Loop + Out
X31.16	AL_COM Loop – Out

Table 15 IO 1 and IO 2

Terminal	Function	
X18.1	+24V Proximity Sensor 1	
X18.2	0V Proximity Sensor 1	
X18.3	Signal Proximity Sensor 1	
X18.4	Steady + Double Door Magnet 1	
X18.5	+24V Door Magnet 1	
X18.6	0V Door Magnet 1	
X18.7	+24V Proximity Sensor 2	Do not connect when used for monitoring the 24V for the proximity sensors
X18.8	0V Proximity Sensor 2	
X18.9	Signal Proximity Sensor 2	
X18.10	Steady + Double Door Magnet 2	
X18.11	+24V Door Magnet 2	
X18.12	0V Door Magnet 2	

Table 16 IO 3 and IO 4

Terminal	Function
X19.1	+24V Proximity Sensor 3
X19.2	0V Proximity Sensor 3
X19.3	Signal Proximity Sensor 3

X19.4	Steady + Double Door Magnet 3
X19.5	+24V Door Magnet 3
X19.6	0V Door Magnet 3
X19.7	+24V Proximity Sensor 4
X19.8	0V Proximity Sensor 4
X19.9	Signal Proximity Sensor 4
X19.10	Steady + Double Door Magnet 4
X19.11	+24V Door Magnet 4
X19.12	0V Door Magnet 4

Table 17 IO 5 and IO 6

Terminal	Door	LLL/LIFT
X20.1	+24V Proximity Sensor 5	Not connected
X20.2	0V Proximity Sensor 5	Activation read back status
X20.3	Signal Proximity Sensor 5	
X20.4	Steady + Double Door Magnet 5	Not connected
X20.5	+24V Door Magnet 5	Potential free dry contacts
X20.6	0V Door Magnet 5	
X20.7	+24V Proximity Sensor 6	Not connected
X20.8	0V Proximity Sensor 6	Power Fault status read-back
X20.9	Signal Proximity Sensor 6	
X20.10	Steady + Double Door Magnet 6	Not connected
X20.11	+24V Door Magnet 6	Potential free dry contacts
X20.12	0V Door Magnet 6	



Table 18 IO 7 and IO 8

Terminal	Door	LLL/LIFT
X21.1	+24V Proximity Sensor 7	Not connected
X21.2	0V Proximity Sensor 7	Activation read back status
X21.3	Signal Proximity Sensor 7	
X21.4	Steady + Double Door Magnet 7	Not connected
X21.5	+24V Door Magnet 7	Potential free dry contacts
X21.6	0V Door Magnet 7	
X21.7	+24V Proximity Sensor 8	Not connected
X21.8	0V Proximity Sensor 8	Power Fault status read-back
X21.9	Signal Proximity Sensor 8	
X21.10	Steady + Double Door Magnet 8	Not connected
X21.11	+24V Door Magnet 8	Power Fault status read-back
X21.12	0V Door Magnet 8	

Table 19 IO 9 and IO 10

Terminal	Function Door	Function LLL/LIFT
X22.1	+24V Proximity Sensor 9	Not connected
X22.2	0V Proximity Sensor 9	Activation read back status
X22.3	Signal Proximity Sensor 9	
X22.4	Steady + Double Door Magnet 9	Not connected
X22.5	+24V Door Magnet 9	Potential free dry contacts
X22.6	0V Door Magnet 9	
X22.7	+24V Proximity Sensor 10	Not connected

X22.8	0V Proximity Sensor 10	Power Fault status read-back
X22.9	Signal Proximity Sensor 10	
X22.10	Steady + Double Door Magnet 10	Not connected
X22.11	+24V Door Magnet 10	Potential free dry contacts
X22.12	0V Door Magnet 10	

### Using more than one BN-305-D in one cabinet for more than 10 doors

The only signals that require external DIN-Rail mounted terminals are the “Main +24V”, “Steady +” and “Common 0V”

